

AUSTRALIAN PRODUCT INFORMATION

ADVATE® (octocog alfa)

1 NAME OF THE MEDICINE

Octocog Alfa.

2 QUALITATIVE AND QUANTITATIVE COMPOSITION

ADVATE powder for injection contains 250, 500, 1000, 1500, 2000, 3000, 4000 International Units (IU) of octocog alfa as the active ingredient.

Composition

ADVATE powder for intravenous injection, after reconstitution with Water for Injection to 2 mL (for strengths 250 IU, 500 IU, 1000 IU and 1500 IU) or 5 mL (across all strengths).

Table 1: Unit Formulation

ADVATE	250 IU	500 IU	1000 IU	1500 IU	2000 IU	3000 IU	4000 IU
Active ingredient: Octocog alfa [Recombinant Coagulation FVIII (rch)]	250 IU	500 IU	1000 IU	1500 IU	2000 IU	3000 IU	4000 IU

The amounts of the inactive ingredients are constant in all strengths.

For the full list of excipients, see Section 6.1 LIST OF EXCIPIENTS.

ADVATE is formulated as a sterile, non-pyrogenic, white to off-white, lyophilised powder preparation of Recombinant Antihemophilic Factor VIII. It is produced from a genetically engineered Chinese Hamster Ovary (CHO) cell-line under conditions, which are free from the use of animal derived protein. ADVATE (rAHF-PFM) is presented in a glass vial accompanied by either a 5 mL (across all strengths) or 2 mL (for strengths 250 IU, 500 IU, 1000 IU and 1500 IU) sterile Water for Injection vial) for reconstitution (see Section 4.2 DOSAGE AND METHOD OF ADMINISTRATION). The reconstituted product is a clear, colourless solution for intravenous (IV) injection.

Trehalose, a disaccharide of two glucose molecules linked by an α, α , glucopyranose of glycoside bond has been used as a stabiliser in the formulation, instead of human albumin as shown in the Table 12 in Section 6.1 LIST OF EXCIPIENTS. The active ingredient, rAHF-PFM, has been manufactured by a method that is free from the use of animal or human derived proteins. This manufacturing process provides a low risk of transmission of blood-borne viruses derived from exogenous human and animal origins.

The molecular integrity and biological activity of rAHF-PFM is indistinguishable from that of the first generation of recombinant Antihemophilic Factor VIII (rAHF). They differ on the culture media used during the manufacturing process and the cell lines. In the first generation of rAHF production, the cell lines are grown in a culture medium containing animal/human derived proteins, whereas in the rAHF-PFM production, the cell lines are

adapted to grow without using animal/human components. The CHO cells transfected with factor VIII gene, express factor VIII within the cell as a glycosylated protein, rAHF-PFM, which is subsequently secreted into the culture medium. The isolation and purification of the rAHF-PFM from the culture medium is basically the same as in the first generation, rAHF, using a series of immunoaffinity chromatography column. In this process, the purification matrix packed into the column was produced by immobilisation of monoclonal antibodies directed to factor VIII to a carrier, which selectively binds the rAHF-PFM. It is followed by the elution of the bound rAHF-PFM from the matrix and subsequently the eluate is subjected to a series of ion-exchange column chromatography procedures to remove the buffer components.

The potency International Units (IU) is determined using the one-stage clotting assay or by chromogenic method (EP), against an in-house standard that is referenced to the FDA/US Mega I Standard. The latter was calibrated against the third WHO standard. The specific activity is approximately 4,000 – 10,000 IU/mg protein.

3 PHARMACEUTICAL FORM

Powder for injection

Appearance

ADVATE is formulated as a sterile, non pyrogenic, white to off-white, lyophilized powder, for intravenous injection in a glass vial. It is supplied in single-dose glass vials containing nominally 250, 500, 1000, 1500, 2000, 3000 IU or 4000 IU per vial and a diluent (Sterile Water for Injection or sWFI) for reconstitution. It is accompanied by either a 5 mL (across all strengths) or 2 mL (for strengths 250 IU, 500 IU, 1000 IU and 1500 IU) sterile Water for Injection vial) for reconstitution (see Section 4.2 DOSAGE AND METHOD OF ADMINISTRATION).

ADVATE with 5 mL of sWFI is available as a lyophilised powder in single-use glass vials containing nominally 250, 500, 1000, 1500, 2000, 3000 or 4000 IU.

ADVATE with 2 mL of sWFI is available as a lyophilised powder in single-use glass vials containing nominally 250, 500, 1000 or 1500 IU.

The reconstituted product is a clear, colourless solution for intravenous (IV) injection.

4 CLINICAL PARTICULARS

4.1 THERAPEUTIC INDICATIONS

ADVATE is indicated for use in haemophilia A for prevention and control of haemorrhagic episodes. Patients with haemophilia A may be treated with ADVATE as perioperative management.

ADVATE is not indicated in von Willebrand's disease.

4.2 DOSE AND METHOD OF ADMINISTRATION

Treatment should be initiated under the supervision of a physician experienced in the management of haemophilia.

Dosage

The dosage and duration of the substitution therapy depend on the severity of factor VIII deficiency, the location and the extent of the bleeding and on the patient's clinical condition. The dose of factor VIII administered is expressed in International Unit (IU), which is related to the WHO standard for factor VIII products. Factor VIII activity in plasma is expressed either as a percentage (relative to normal human plasma) or in IUs (relative to the international standard for factor VIII in plasma).

One International Units of factor VIII activity is equivalent to that quantity of factor VIII in one mL of normal human plasma. The calculation of the required dosage of factor VIII is based on the empirical finding that 1 International Units factor VIII per kg body weight raises the plasma factor VIII activity by 2 International Units /dL. The dose is determined using the following formula and tables 2 and 3.

Formula

Required units (International Units) = body weight (kg) x desired factor VIII rise (%) x 0.5

Control and prevention of bleeding episodes

A guide for dosing in the treatment of bleeding episodes is provided in Table 2 below. The careful control of treatment dose is especially important in cases of life-threatening bleeding episodes.

Table 2: ADVATE Dosing for Treatment of Bleeding Episodes in Adults and Children.

Type of Bleeding Episodes	Required Peak Post-infusion Factor VIII Activity in the Blood (as % of Normal or IU/dL)	Dosage and Frequency Necessary to Maintain the Therapeutic Plasma Level
Minor Early haemarthrosis, mild muscle bleeding, or mild oral bleeding episode.	20-40	10-20 International Units per kg ^a Repeat infusions every 12 to 24 hours (8 to 24 hours for patients under the age of 6) for one to three days until the bleeding episode is resolved (as indicated by relief of pain) or healing is achieved.
Moderate Moderate bleeding into muscles, bleeding into the oral cavity, definite haemarthrosis, and known trauma.	30-60	15-30 International Units per kg ^a Repeat infusions every 12 to 24 hours (8 to 24 hours for patients under the age of 6) for three days or more until the bleeding episode is resolved (as indicated by relief of pain) or healing is achieved.
Major Significant gastrointestinal bleeding, intracranial, intra-abdominal or intrathoracic bleeding, central nervous system bleeding, bleeding in the retropharyngeal or retroperitoneal spaces or iliopsoas sheath, fractures, head trauma.	60-100	Initial dose 30-50 International Units per kg ^a Repeat dose 30-50 International Units per kg every 8 to 24 hours (6 to 12 hours for patients under the age of 6) until resolution of the bleeding episode has occurred.

^a Dose (IU/kg) = Desired Factor VIII Rise (IU/dL or % of normal) x 0.5 (IU/kg per IU/dL).

Perioperative management

A guide for dosing in perioperative management is provided in Table 3 below. The careful control of dose and duration of treatment is especially important in cases of major surgery.

Table 3: ADVATE Dosing for Perioperative Management in Adults and Children

Type of Surgery	Required Peak Post-infusion Factor VIII Activity in the Blood (% of Normal or IU/dL)	Frequency of Infusion
Minor Including tooth extraction	60-100	A single bolus infusion (30-50 International Units/kg ^a) beginning within one hour of the operation. Optional additional dosing every 12 to 24 hours as needed to control bleeding. For dental procedures, adjunctive therapy may be considered.
Major Examples include intracranial, intra-abdominal, or intrathoracic surgery, joint replacement surgery	80-120 (pre- and post-operative)	Preoperative bolus infusion: 40 – 60 International Units/kg ^a . Verify 100% activity has been achieved prior to surgery. Maintenance bolus infusion (40-60 International Units/kg ^a) repeat infusions every 8 to 24 hours (6 to 24 hours for patients under the age of 6), depending on the desired level of Factor VIII and state of wound healing.

^a Dose (IU/kg) = Desired Factor VIII Rise (IU/dL or % of normal) x 0.5 (IU/kg per IU/dL).

In case of the haemorrhagic events as shown in table 10, the factor VIII activity should not fall below the given plasma activity level (in % normal or International Units /dL) in the corresponding period. The above table can be used to guide dosing in bleeding episodes and surgery.

The amount and frequency of administration should be adapted to the clinical effectiveness of the product in the individual case. Under certain circumstances (presence of a low responder inhibitor) doses larger than the calculated doses may be necessary.

Careful control of replacement therapy is especially important in cases of major surgery or life threatening haemorrhages. During the course of treatment, appropriate determination of plasma factor VIII levels is advised to guide the dose to be administered and the frequency of repeated infusions. In the case of major surgical interventions in particular, precise monitoring of the substitution therapy by means of plasma factor VIII activity assay is indispensable. Individual patients may vary in their response to factor VIII, achieving different levels of *in vivo* recovery and demonstrating different half-lives.

Prophylaxis

For prevention of bleeding episodes, doses between 20 to 40 International Units of Factor VIII per kg body weight every other day (3 to 4 times weekly) may be utilised. In some cases, especially in younger patients, shorter dose intervals or higher doses may be necessary.

A PK-guided every third day dosing regimen with 20 to 80 IU per kg body weight targeting maintenance of FVIII trough levels $\geq 1\%$ may also be employed. A PK evaluation of a patient's individual response to ADVATE should be conducted to determine the weight-adjusted dose for PK-guided prophylaxis. In younger patients, it is advised that PK evaluations should be performed periodically.

Pharmacokinetic evaluations may be performed using a traditional PK evaluation method; however, alternative methods of PK evaluation using fewer blood samples may be considered.

Patients with inhibitors

Patients should be evaluated for the development of factor VIII inhibitors, if the expected plasma factor VIII activity levels are not attained, or if bleeding is not controlled with an appropriate dose. In patients with high levels of inhibitor, factor VIII therapy may not be effective and other therapeutic options should be considered. Management of such patients should be directed by physicians with experience in the care of patients with haemophilia A (see Section 4.4 SPECIAL WARNINGS AND PRECAUTIONS FOR USE/Inhibitor formation).

Laboratory tests

Although dosage can be estimated by the calculations as described above, it is strongly recommended that, whenever possible, appropriate laboratory tests including serial AHF assays be performed on the patient's plasma at suitable intervals to ensure that adequate AHF levels have been reached and maintained.

If bleeding is not controlled with the recommended dose, the plasma level of Factor VIII should be determined and a sufficient dose of ADVATE should be administered to achieve a satisfactory clinical response.

If the patient's plasma factor VIII fails to reach the expected levels or if bleeding is not controlled after adequate dosage, the presence of inhibitor should be suspected. By performing appropriate laboratory investigations, the presence of an inhibitor can be demonstrated and quantified in terms of IU factor VIII neutralised by each mL of plasma. If the inhibitor is present at a level of less than 10 BU/mL, administration of additional factor VIII may neutralise the inhibitor. Thereafter, the administration of additional factor VIII should elicit the predicted response. The control of factor VIII and inhibitor levels by laboratory assays is necessary in this situation. Inhibitor titres above 10 BU/mL may make haemostatic control with factor VIII either impossible or impractical because of the large dose required. In addition, the inhibitor titre may rise following AHF infusion because of an anamnestic response to factor VIII.

Administration

Instructions for use, handling and disposal

Use Aseptic Technique.

The preparation is to be administered intravenously after reconstitution with the provided sterilised water for injections. Parenteral drug products should be inspected for particulate matter and discoloration prior to administration, whenever solution and container permit. A colourless appearance is acceptable for ADVATE.

Do not refrigerate the preparation after reconstitution. ADVATE should be administered at room temperature not more than 3 hours after reconstitution.

Plastic syringes must be used with this product, since proteins such as ADVATE tend to stick to the surface of the glass syringes.

Discard any unused preparation appropriately; see Section 6.6 SPECIAL PRECAUTIONS FOR DISPOSAL.

Do not use after the expiry date printed on the label.

Reconstitution using the BAXJECT II Device

1. Bring ADVATE (dry factor concentrate) and Sterile Water for Injections (diluent) to room temperature (25°C).
 2. Remove caps from the factor concentrate and diluents vials.
 3. Cleanse stoppers with a germicidal solution and allow to dry prior to use. Place the vials on a flat surface.
 4. Open the BAXJECT II device package by peeling away the lid, without touching the inside (**Figure A**). Do not remove the device from the package.
 5. Turn the package over. Press straight down to fully insert the clear plastic spike through the diluents vial stopper (**Figure B**).
 6. Grip the BAXJECT II package at its edge and pull the package off the device (**Figure C**). Do not remove the blue cap from the BAXJECT II device. Do not touch the exposed white plastic spike.
 7. Turn the system over, so that the diluents vial is on top. Quickly insert the white plastic spike fully into the ADVATE vial stopper by pushing straight down (**Figure D**). The vacuum will draw the diluents into the ADVATE vial.
 8. Swirl gently until ADVATE is completely dissolved.
- NOTE: Do not refrigerate after reconstitution.
9. Remove the blue cap from the BAXJECT II device. Connect the syringe to the BAXJECT II device (**Figure E**). DO NOT INJECT AIR.
 10. Turn the system upside down (factor concentrate vial now on top). Draw the factor concentrate into the syringe by pulling the plunger back slowly (**Figure F**).
 11. Disconnect the syringe, attach a suitable needle and inject intravenously as instructed under Administration by Bolus Infusion.
 12. If a patient is to receive more than one vial of ADVATE, the contents of multiple vials may be drawn into the same syringe. Please note that the BAXJECT II reconstitution device is intended for use with a single vial of ADVATE and Sterile Water for Injections only, therefore reconstituting and withdrawing second vial into the syringe requires a second BAXJECT II reconstitution device.

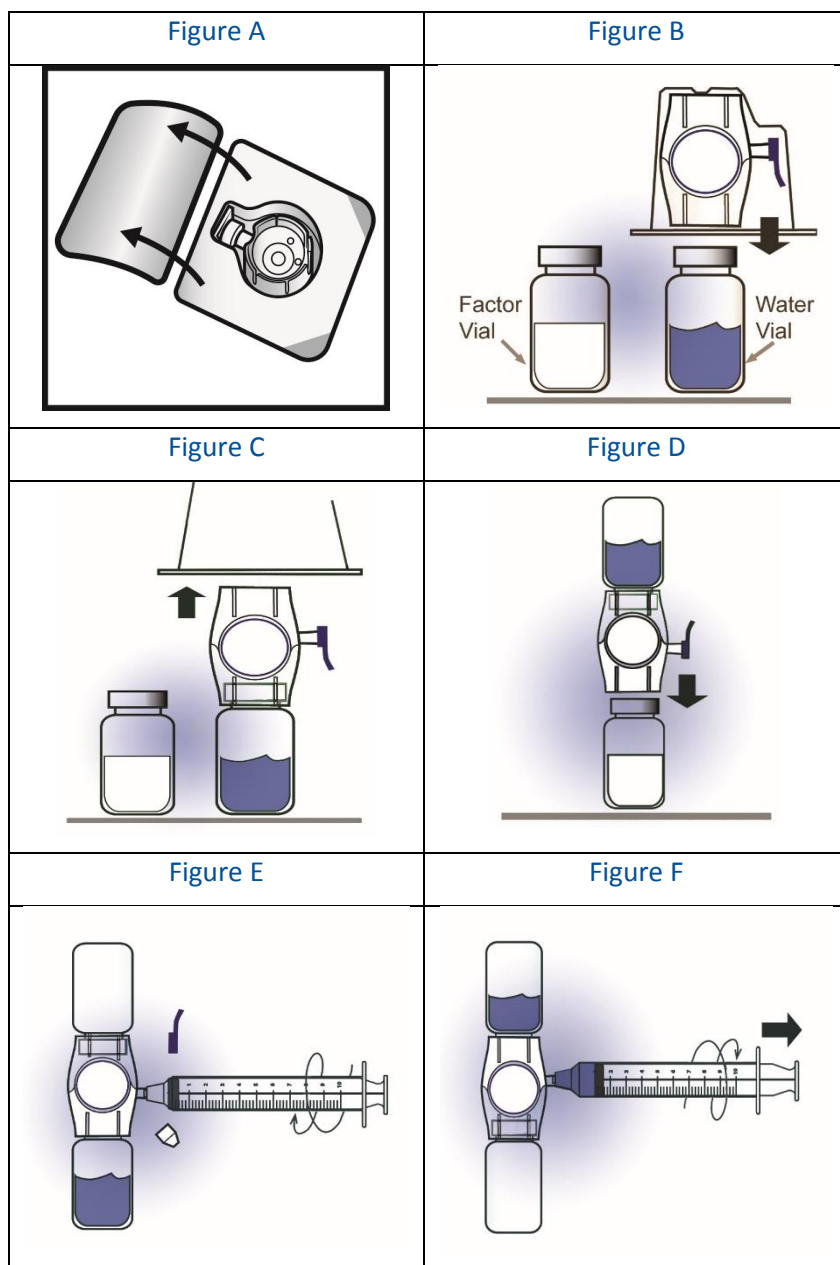

Reconstitution of ADVATE in a BAXJECT III Device

1. Bring the BAXJECT III device pre-assembled with ADVATE and diluent vials to room temperature (25°C).
2. Open the ADVATE package by peeling away the lid. Remove ADVATE in the BAXJECT III system from the package and verify that the expiration date on the label has not passed and the potency unit number is same as expected.
3. Place the ADVATE on a flat surface with the diluent vial on top (**Figure 1**). The diluent vial has a blue stripe. *Do not remove the blue cap until instructed in a later step.*
4. With one hand holding the ADVATE in the BAXJECT III system, press down firmly on the diluent vial with the other hand until the system is fully collapsed and the diluent flows down into the ADVATE vial (**Figure 2**). Do not tilt the system until the transfer is complete.
5. Verify that diluent transfer is complete. Swirl gently until ADVATE is completely dissolved (**Figure 3**). **Do not shake. Do not refrigerate after reconstitution.** Inspect

parenteral drug products for particulate matter and discoloration prior to administration. The solution should be clear and colorless in appearance. If not, do not use the solution and notify Shire immediately.

6. Remove the blue cap from the BAXJECT III system. Connect the syringe to the system (**Figure 4**). *Do not inject air into the BAXJECT III system.*

7. Turn the system upside down (factor concentrate vial now on top). Draw the factor concentrate into the syringe by pulling the plunger back slowly (**Figure 5**).

8. Disconnect the syringe; attach a suitable needle and inject intravenously as instructed under *Administration by Bolus Infusion*. If a patient is to receive more than one ADVATE in a BAXJECT III system or a combination of ADVATE and BAXJECT II and an ADVATE in a BAXJECT III system, the contents may be drawn into the same syringe.

Figure 1

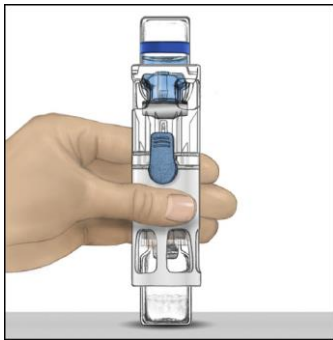

Figure 2

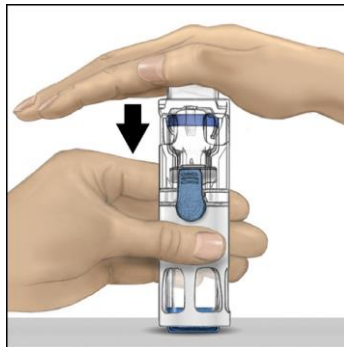

Figure 3

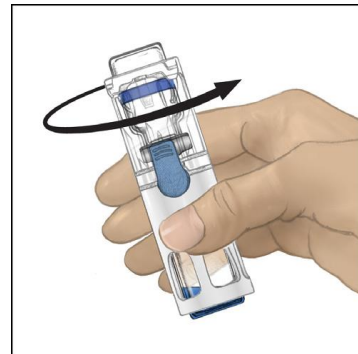

Figure 4

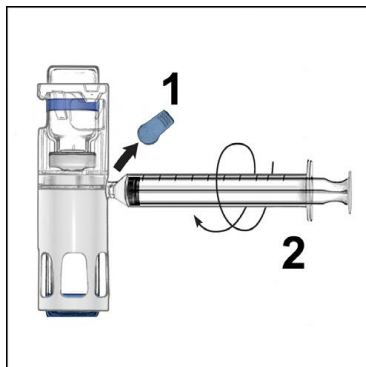
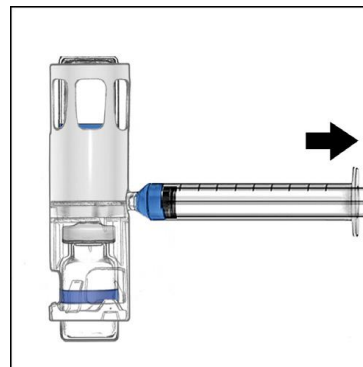

Figure 5



Administration by Bolus Infusion

A dose of ADVATE should be administered over a period of < 5 minutes (maximum infusion rate 10mL/min). The pulse rate should be determined before and during administration of ADVATE. Should a significant increase in pulse rate occur, reducing the rate of administration or temporarily halting the injection usually allows the symptoms to disappear promptly.

Administration by continuous infusion

The 1500, 1000 and 500 IU/vial strengths of ADVATE are suitable for use in a continuous infusion mode of administration. However, it is not recommended to use continuous infusion for the administration of the 2000 IU, 3000 IU, and 4000 IU strengths. Continuous infusion of ADVATE must employ either a syringe pump running at a rate of greater than or equal to 0.4 mL/hour, or a CADD-1 type infusion pump running at a rate of 1.5 mL/hour. *In vitro* studies employing a syringe pump or CADD-1 pump have demonstrated > 80 % of the hour 0 potency of ADVATE for up to 48 hours of continuous infusion. For sterility assurance purposes, a fresh supply of reconstituted ADVATE for continuous infusion (prepared under laminar air flow conditions) should be replaced at bedside no less frequently than every 12 hours. The post-reconstitution photostability of ADVATE is acceptable under the conditions of visible and ultra-violet light exposure in a clinical setting. It is highly recommended that factor VIII levels be checked within 3 to 6 hours after the initiation of continuous infusion in order to document that the desired factor VIII levels are being maintained.

Rates of infusion should be modified based on the levels of plasma factor VIII activity measured at least once per day thereafter and based on the desired level of factor VIII.

4.3 CONTRAINDICATIONS

Known hypersensitivity to any component or to mouse or hamster proteins.

4.4 SPECIAL WARNINGS AND PRECAUTIONS FOR USE

Hypersensitivity reactions

Allergic-type hypersensitivity reactions, including anaphylaxis, have been reported with ADVATE and have been manifested by dizziness, paresthesia, rash, flushing, face swelling, urticaria, and pruritus.

Patients should be informed of the signs of hypersensitivity reactions (including hives, generalized urticaria, tightness of the chest, wheezing, hypotension and anaphylaxis). If these symptoms occur, they should be advised to discontinue use of the product immediately and contact their physicians. In the case of anaphylactic shock, the current medical standards for shock treatment should be implemented.

In children aged 0 to 18 years, due to the decrease in injection volume for ADVATE reconstituted in 2 mL, the time to react to hypersensitivity reactions during an injection is further reduced. Therefore, caution is advised during injection of ADVATE reconstituted in 2 ml, especially in children. Patients newly initiated on ADVATE should consider commencing on the 5 mL sWFI diluent to increase the time frame for management of a potential hypersensitivity reaction.

Inhibitor formation

The formation of neutralising antibodies (inhibitors) to factor VIII is a known complication in the management of individuals with haemophilia A. In particular when the subject has not been treated with antihaemophilic factor VIII previously, the chance of antibodies formation is high. These inhibitors are usually IgG immunoglobulins directed against factor VIII procoagulant activity, which are quantified in Bethesda Units (BU) per mL of plasma using the modified Bethesda assay.

The risk of developing inhibitors is correlated to the extent of exposure to the factor VIII, the risk is being highest within the first 20 exposure days. Rarely, inhibitors may develop after

the first 100 exposure days. Patients treated with ADVATE should be carefully monitored for the development of inhibitors by appropriate clinical observations and laboratory tests. Inhibitors have predominantly been reported in previously untreated patients.

The risk for inhibitor development depends on a number of factors relating to the characteristics of the patient, e.g. type of the Factor VIII gene mutation, family history, ethnicity, which are believed to represent the most significant risk factors for inhibitor formation. Risk factors include non-caucasians, polymorphisms in TNF- α or IL-10, intensive high dose treatments and surgery.

Among 136 treated subjects greater or equal to 10 years of age, all of whom had > 150 exposure days to Factor VIII at study entry, 102 had at least 75 exposure days to ADVATE rAHF-PFM. None of these subjects developed an inhibitor. One subject who had < 50 exposure days to ADVATE (rAHF-PFM) while on the study developed an inhibitor. This subject manifested a low titre inhibitor (2.0 BU by the Bethesda assay) after 26 exposure days with ADVATE (rAHF-PFM). Follow-up inhibitor tests in this subject after withdrawal from the study were negative.

Of the 55 previously untreated patients (PUP's) who participated in the Advate PUP study, 16 subjects developed inhibitors: 7 subjects developed high-titre inhibitors and 9 subjects developed low-titre inhibitors, 1 of which was also classified as a transient inhibitor.

Antibodies against Mouse or Hamster (CHO) proteins

ADVATE (rAHF-PFM) contains trace amounts of mouse immunoglobulin G (MuIgG); maximum level of 0.1 ng/IU and hamster (CHO) proteins (maximum levels of 1.5 ng/IU). As such, there exists a remote possibility that patients treated with this product may develop hypersensitivity to these non-human derived proteins.

In the Phase 2/3 pivotal study of ADVATE (rAHF-PFM), serum samples were tested by enzyme immunoassays at base line and after every 15 ± 2 days for the presence of antibodies to CHO proteins and MuIgG. Four study subjects showed a statistically significant increasing trend in the levels of anti-CHO (n=1) or anti-MuIgG (n=3) antibody levels over the course of the study. A fifth study subject showed a marked increase in anti-MuIgG antibodies coincident with the 60 and 75 day interval study visits. None of these subjects exhibited adverse experiences (AEs) or other study findings consistent with an allergic or hypersensitivity response.

Use in the elderly

It is not known whether elderly patients respond differently from younger subjects. As for all patients, dose selection for an elderly patient should be individualised.

Paediatric use

Other than the increased incidence development of inhibitors in previously untreated paediatric patients (PUPs), and catheter-related complications, no age-specific differences in side effects were noted in the clinical studies.

Due to the decrease in injection volume for ADVATE reconstituted in 2 mL, the time to react to hypersensitivity reactions during an injection is further reduced. Therefore, caution is advised during injection of ADVATE reconstituted in 2 mL, especially in children.

Effects on laboratory tests

See Section 4.2 DOSE AND METHOD OF ADMINISTRATION/Laboratory tests.

4.5 INTERACTIONS WITH OTHER MEDICINES AND OTHER FORMS OF INTERACTIONS

No interactions of ADVATE with other medicinal products are currently known, based upon the absence of data from clinical trials, current medical/scientific literature, and post marketing safety reports.

4.6 FERTILITY, PREGNANCY AND LACTATION

Effects on fertility

Animal studies examining the effects of ADVATE on fertility have not been conducted.

Use in pregnancy

Australian Pregnancy Categorisation (Category B2)

Factor VIII deficiency is an X-chromosome linked (male) congenital disease. Based on the rare occurrence of haemophilia A in women, experience regarding the use of Factor VIII during pregnancy is not available. The safety of ADVATE for use in pregnant women has not been established. Physicians should balance the potential risks and only prescribe if clearly needed. Animal reproduction studies with recombinant factor VIII, including ADVATE, have not been conducted.

Use in lactation

Based on the rare occurrence of haemophilia A in women, experience regarding the use of factor VIII during breast-feeding is not available. It is not known if ADVATE or its metabolites are excreted in human milk. The safety of ADVATE for use in lactating women has not been established. Breastfeeding is not recommended in women being treated with ADVATE. Physicians should carefully consider the potential risks and benefits for each specific patient before prescribing ADVATE.

4.7 EFFECTS ON ABILITY TO DRIVE AND USE MACHINES

There is no information on the effects of ADVATE on the ability to drive or operate an automobile or other heavy machinery.

4.8 ADVERSE EFFECTS (UNDESIRABLE EFFECTS)

Although hypersensitivity or allergic reactions were not observed in any subjects participating in the clinical trials with ADVATE, such reactions have been reported in the post-marketing setting. Patients should be informed of the early signs of hypersensitivity reactions, which may include nausea, vomiting, rash, urticaria, dizziness, shortness of breath, hypotension and syncope. Patients should be advised to contact their physician if these symptoms occur.

Adverse Reactions from Clinical Trials

Clinical Studies with ADVATE enrolled 450 unique subjects. The safety analysis set included 418 subjects with at least one exposure to ADVATE from 12 clinical studies: 069901, 060102, BLB-200-01, 060101, 060401, 069902, 060201, 060103, 060403, 060702, 060601, and 060801.

A total of 93 adverse reactions (ADR) were reported in 45 of the 418 unique treated subjects. The most common adverse reaction included FVIII inhibition, pyrexia, and headache. Of these, 17 ADRs for FVIII inhibition were considered serious. Factor VIII inhibition was the most frequent ADR that was reported in 4.1% of treated subjects (n=17). Of the 93 ADRs, none were reported in neonates (0 to < 1 month of age), 30 ADRs were reported in 20/60 infants (1 month to <2 years of age), 7 ADRs were reported in 3/68 children (2 to <12 years of age), 10 ADRs were reported in 5/38 adolescents (12 to <16 years of age), and 46 ADRs were reported in 17/147 adults (16 years of age and older).

Table 4: ADVATE CCDS Clinical Study Adverse Reactions^a

System Organ Class (SOC)	Preferred MedDRA Term (Version 15.1)	Number of Unique Subjects	ADR Rate (% of subjects) ^b	Frequency Category
Infections and infestations	Influenza	1	0.24	Uncommon
	Laryngitis	1	0.24	Uncommon
Blood and lymphatic system disorders	Factor VIII inhibition ^c	17	4.07	Common
	Lymphangitis	1	0.24	Uncommon
Nervous system disorders	Headache	7	1.67	Common
	Dizziness	4	0.96	Uncommon
	Dysgeusia	1	0.24	Uncommon
	Memory impairment	1	0.24	Uncommon
	Migraine	1	0.24	Uncommon
	Syncope	1	0.24	Uncommon
	Tremor	1	0.24	Uncommon
Eye disorders	Eye inflammation	1	0.24	Uncommon
Cardiac disorders	Palpitations	1	0.24	Uncommon
Vascular disorders	Hematoma	1	0.24	Uncommon
	Hot flush	2	0.48	Uncommon
	Pallor	1	0.24	Uncommon
Respiratory, thoracic and mediastinal disorders	Dyspnea	2	0.48	Uncommon
Gastrointestinal disorders	Abdominal pain upper	2	0.48	Uncommon
	Diarrhea	2	0.48	Uncommon
	Nausea	1	0.24	Uncommon
	Vomiting	1	0.24	Uncommon
Skin and subcutaneous tissue disorders	Hyperhidrosis	2	0.48	Uncommon
	Pruritus	2	0.48	Uncommon
	Rash	4	0.96	Uncommon
	Urticaria	1	0.24	Uncommon
General disorders and administration site conditions	Pyrexia	6	1.44	Common
	Chest discomfort	1	0.24	Uncommon
	Chest pain	1	0.24	Uncommon
	Chills	1	0.24	Uncommon
	Feeling abnormal	1	0.24	Uncommon
	Peripheral edema	1	0.24	Uncommon
	Vessel puncture site hematoma	1	0.24	Uncommon

System Organ Class (SOC)	Preferred MedDRA Term (Version 15.1)	Number of Unique Subjects	ADR Rate (% of subjects) ^b	Frequency Category
Investigations	Coagulation factor VIII level decreased	1	0.24	Uncommon
	Hematocrit decreased	1	0.24	Uncommon
	Laboratory test abnormal	1	0.24	Uncommon
	Monocyte count increased	1	0.24	Uncommon
Injury, poisoning and procedural complications	Post procedural complication	1	0.24	Uncommon
	Post procedural hemorrhage	1	0.24	Uncommon
	Procedural site reaction	1	0.24	Uncommon

Legend: ADR frequency is based upon the following scale: Very Common ($\geq 1/10$); Common ($\geq 1/100 - < 1/10$), Uncommon ($\geq 1/1,000 - < 1/100$), Rare ($\geq 1/10,000 - < 1/1,000$), Very Rare ($< 1/10,000$)

^a ADRs are defined as all ADRs related to investigational product: 93.

^b Percent is based on total number of subjects who received ADVATE: 418.

^c In study 060103 (PUP), 16 subjects reported an ADR for inhibitor development. In study 060201, one subject reported an ADR for inhibitor development that was not confirmed. In study 069901, one subject had an inhibitor that was not reported as an ADR. In total, there were 17 confirmed inhibitors reported in 17 subjects.

A total of 276 patients, diagnosed with severe to moderately severe hemophilia A (FVIII $\leq 2\%$), entered studies that required a minimum of 150 exposure days in adults and older children and 50 exposure days in children < 6 years of age to factor VIII concentrates prior to participation. Among these patients, one displayed evidence of a factor VIII inhibitor. This subject manifested a low titre inhibitor (2.0 BU by the Bethesda assay) after 26 exposure days. Follow-up inhibitor tests in this subject after withdrawal from the study were negative. Across all studies, median exposure to ADVATE was 97.0 exposure days per subject (range 1 to 709) for previously treated patients. The overall incidence and 95% CI of any FVIII inhibitor development (low or high) was 0.36% (1 of 276), the 95% CIs: 0.009 to 2.002% based on 276 previously treated patients. The incident results for low titre and overall titre (low and high) were the same. The high titre incidence and 95% CI of FVIII inhibitor development was 0.00% (0 of 276), the 95% CIs: 0.000 to 1.328%.

In addition, 16 out of 55 previously untreated patients developed FVIII inhibitors: 7 subjects developed high-titre inhibitors and 9 subjects developed low-titre inhibitors, 1 of which was also classified as a transient inhibitor.

Post-Marketing Adverse Reactions

In addition to the adverse reactions noted in clinical trials, the following adverse reactions have been reported in the post-marketing experience. These adverse reactions are listed by preferred MedDRA (Version 15.1) term in order of severity.

IMMUNE SYSTEM DISORDERS: Anaphylactic reaction, hypersensitivity

BLOOD AND LYMPHATIC SYSTEM DISORDERS: Factor VIII inhibition

GENERAL AND ADMINISTRATION SITE CONDITIONS: Injection site reaction, fatigue, malaise

Reporting Suspected Adverse Effects

Reporting suspected adverse reactions after registration of the medicinal product is important. It allows continued monitoring of the benefit-risk balance of the medicinal product. Healthcare professionals are asked to report any suspected adverse reactions at <http://www.tga.gov.au/reporting-problems>.

4.9 OVERDOSE

There has been no reported clinical adverse experience that could be associated with overdosage.

For information on the management of overdose, contact the Poisons Information Centre telephone: 131126 (Australia).

5 PHARMACOLOGICAL PROPERTIES

5.1 PHARMACODYNAMIC PROPERTIES

Mechanism of Action

Under normal physiological conditions, factor VIII is essential for blood clotting and haemostasis. The activated factor VIII (FVIIIa) acts as a cofactor for activating factor IX to IXa cascading to activate factor X to Xa. By the actions of the activated factors Va and Xa, circulating pro-thrombin is converted into thrombin. Subsequently, thrombin converts fibrinogen to fibrin monomer cascading to formation of linear fibrin polymer. By the action of factor XIII the fibrin monomer is cross-linked to form fibrin clots leading to the arrest of bleeding episodes.

In patients with haemophilia A (classical haemophilia), a sex-linked hereditary disorder of blood coagulation, the level of circulating factor VIII is decreased, leading to profuse bleeding into joints, muscles or internal organs, either spontaneously or as a result of accidental or surgical trauma. The use of plasma-derived or recombinant derived factor VIII has been shown successfully to correct this deficiency. Thus, plasma derived and recombinant derived factor VIII has the same pharmacological actions.

Clinical trials

Original safety and efficacy study

In the phase 2/3 pivotal study, a global assessment of efficacy was rendered either by the subject (for home treatment) or study site investigator (for treatment under medical supervision) using an ordinal scale of excellent, good, fair, or none, based on the quality of haemostasis achieved with ADVATE (rAHF-PFM). A total of 510 bleeding episodes were reported, with a mean (\pm SD) of 6.1 ± 8.2 bleeding episodes per subject. Of the 510 new bleeding episodes treated with ADVATE (rAHF-PFM), 439 (86%) were rated excellent or good in their response to treatment, 61 (12%) were rated fair, 1 (0.2%) was rated as having no response, and for 9 (2%), the response to the treatment was unknown. A total of 411 (81%) new bleeding episodes were managed with a single infusion, 62 (12%) required 2 infusions, 15 (3%) required 3 infusions, and 22 (4%) received 4 or more infusions of ADVATE (rAHF-PFM) for satisfactory resolution. A total of 162 (32%) new bleeding episodes occurred spontaneously, 228 (45%) were the result of antecedent trauma, and for 120 (24%) bleeding episodes the etiology was unknown.

The rate of new bleeding episodes during the protocol-mandated minimum of 75 exposure day prophylactic regimen (≥ 25 IU/kg body weight 3 – 4 times per week) was calculated as a function of the bleeding episodes for 107 evaluable subjects (n=274 new bleeding episodes). These rates are presented in Table 5.

Table 5: Rate of New Bleeding Episodes During Prophylaxis

Bleeding Episode Etiology	Mean (\pm SD) New Bleeding Episodes/Subjects/Month
Spontaneous	0.34 \pm 0.49
Post Traumatic	0.39 \pm 0.46
Unknown*	0.33 \pm 0.34
Overall	0.52 \pm 0.71

* Etiology was indeterminate.

In a *post-hoc* analysis, the overall rate of bleeding was correlated with the degree of compliance with the prescribed prophylactic regimen. Subjects who infused less than 25 IU ADVATE (rAHF-PFM) per kg per dose for more than 20% of prophylactic infusions or administered less than 3 infusions per week for more than 20% of study weeks (n=37) experienced a 2.3-fold higher rate of bleeding in comparison with subjects who complied with prescribed prophylactic regimen at least 80% of the time and at $\geq 80\%$ of the prescribed dose (n=70).

The phase 2/3 continuation study involved subjects previously treated in the pivotal Phase 2/3 study and provided additional data on ADVATE (rAHF-PFM). An interim analysis of efficacy was conducted for 27 of 82 enrolled subjects who self-administered ADVATE (rAHF-PFM) on routine prophylactic regimen during a minimum period of 50 exposures days to ADVATE (rAHF-PFM). As in the pivotal Phase 2/3 study, new bleeding episodes were treated with ADVATE (rAHF-PFM) and the outcome of the treatment was rated as excellent, good, fair, or none, based on the quality of haemostasis achieved. A total of 51 new bleeding episodes occurred in 13 of the 27 subjects being treated with ADVATE (rAHF-PFM). By etiology, 53% of these bleeding events resulted from trauma and 27% occurred spontaneously; the remaining 20% had an undetermined etiology. The response to treatment with ADVATE (rAHF-PFM) for the majority (63%) of all new bleeding episodes was rated as excellent or good. In addition, 86% of the bleeding episodes resolved with only 1 infusion and an additional 6% were resolved by a second infusion. Thus, 92% of the bleeding episodes required 1 or 2 infusions of study product.

An interim analysis of the haemostatic efficacy of ADVATE (rAHF-PFM) during the perioperative management of subjects undergoing surgical procedures was conducted for 10 of 25 planned subjects. Ten subjects underwent 10 surgical procedures while receiving ADVATE (rAHF-PFM). Eight subjects received the test product by intermittent bolus infusion and 2 subjects received a combination of continuous and intermittent bolus infusion. Nine of 10 subjects completed the study. Six of the surgical procedures were classified as major, and 4 were minor. Of the 6 major surgeries, 5 were for orthopaedic complications of haemophilia. A brief description of each surgical procedure, along with study duration and study medication exposure, are presented in Table 6.

Table 6: Surgical Procedures, Study Duration, and Study Medication Exposure

Surgery Type	Days of Study	ADVATE (rAHF-PFM) Exposure Days	Cumulative ADVATE (rAHF-PFM) Exposure (IU)
Total hip replacement	16	15	61,600
Knee joint replacement	22	18	76,060
Knee Arthrodesis	24	22	66,080
Transposition of the left ulnar nerve	5	3	14,560
Insertion of Mediport	28	8*	46,893
Dental Extraction	18	6	16,599
Left elbow synovectomy	43	32	102,180
Teeth Extraction	2	2	10,350
Right knee arthroscopy, chondroplasty, and synovectomy	13	10*	32,334
Wisdom teeth Extraction	14	5	15,357

*ADVATE (rAHF-PFM) was administered by continuous infusion for the first 48 hours post-operatively, followed by bolus infusions for the remainder of study treatment.

For each of the 10 subjects, intra- and post-operative quality of haemostasis with ADVATE (rAHF-PFM) was assessed by operating surgeon and study site investigator, respectively, using ordinal scale of excellent, good, fair, or none. The same rating scale was used to evaluate control of haemorrhage from a surgical drain placed at the incision site in one subject. The quality of haemostasis achieved with ADVATE (rAHF-PFM) was rated as excellent or good for all assessments.

Randomised Prophylaxis Study

In a multicentre, open-label, prospective, randomised, controlled post-marketing clinical study (060201) of ADVATE use in 2 prophylactic treatment regimens compared to that of on-demand treatment, 53 PTPs with severe to moderately severe Haemophilia A (FVIII level ≤ 2 IU/dL) were analysed in the per-protocol group. Subjects were initially treated for 6 months of on-demand therapy and then randomised to 12 months of either a standard prophylaxis regimen (20-40 IU/kg every 48 hours) or PK-guided prophylaxis regimen (20-80 IU/kg every 72 hours). All subjects had a history of at least 8 joint haemorrhages within 12 months prior to entering the study. Each subject in the per protocol group was adherent to > 90% of the prescribed number of prophylactic infusions; no subject in the study surpassed the upper boundary of 110% of the prescribed number of prophylactic infusions.

The median annual bleed rate for the PP group during the on-demand therapy period was 44 bleeds per subject per year compared to 1 bleed per subject per year while on either prophylaxis regimen, which was a statistically significant difference ($p < 0.0001$). Twenty-two of 53 (42%) subjects experienced no bleeding episodes while on prophylaxis for one year. There was no statistically significant difference in bleeding frequency observed between the two prophylaxis regimens studied. The study was designed to detect a difference between the two prophylaxis arms of 2.5 bleeds per annum at 80% power when at least 30 subjects were in each treatment arm. The number of patients in the per protocol analysis (standard prophylaxis $n=30$, PK-guided prophylaxis $n=23$) did not meet this criteria. The formula used to determine the weight-adjusted dose of the product used in the PK-guided prophylaxis arm, as calculated from the individual subject's incremental recovery and half-life values to achieve a trough level of ≥ 1 IU/dL at the inter-dosing interval of 72 hours is defined as follows:

$$D = (2)^{72/t} / r$$

D = target FVIII dose (IU/kg) that ensures that a trough level of ≥ 1 IU/dL is achieved after 72 hours

r = FVIII incremental recovery (IU/dL / IU/kg) as determined by the subject's PK analysis

t = FVIII half-life (hrs) as determined by the subject's PK analysis

Table 7: Annual Bleed Rate of Prophylaxis Compared to On-Demand Treatment

Clinical Parameters	On -Demand (n=53)	Standard Prophylaxis (n=30)	PK-guided Prophylaxis (n=23)	Either Standard or PK-guided Prophylaxis (n=53)
Median (IQR) ¹ Annual Bleed Rate (ABR)	44.0 (20.8)	1.0 (2.1)	1.0 (4.1)	1.0 (4.1)
Median (IQR) ¹ Joint ABR	38.7 (24.8)	0.5 (2.0)	1.0 (4.1)	1.0 (2.1)
Median (IQR) ¹ Non-Joint ABR ¹	4.0 (11.9)	0.0 (0.0)	0.0 (0.0)	0.0 (0.0)
Median (IQR) ¹ Spontaneous ABR	32.0 (26.8)	0.0 (1.9)	0.0 (2.0)	0.0 (1.9)
Median (IQR) ¹ Traumatic ABR	11.5 (17.2)	0.0 (1.0)	1.0 (1.0)	0.0 (1.0)

¹ Inter-quartile-range (IQR) is defined as the difference between the 75th percentile (3rd quartile) and the 25th percentile (first quartile).

The annualised bleed rates by age category during on-demand and either standard or PK-guided prophylaxis regimens are shown in Table 8.

Table 8: Annualised Bleed Rate by Age category and Any Prophylaxis vs On-Demand (Per Protocol)

Age category	Any Prophylaxis					On-Demand				
	N	Min	Median	Max	Percentage of Subjects With Zero Bleeds	N	Min	Median	Max	Percentage of Subjects With Zero Bleeds
Children (≥ 7 to < 12 years old)	3	0.0	5.2	8.7	33%	3	38.6	44.0	120.5	All subjects bled during On-Demand
Adolescents (≥ 12 to < 16 years old)	4	0.0	5.0	10.0	25%	4	37.9	58.0	81.4	
Adults (≥ 16 years old and older)	46	0.0	1.0	17.4	43%	46	22.7	44.7	117.8	
All Subjects	53	0.0	1.0	17.4	42%	53	22.7	44.0	120.5	

As a secondary endpoint, the study assessed all Short Form Health Survey (SF-36v1) domains. The SF-36v1 is a valid and reliable measure of health-related quality of life that is comprised of 8 domain and 2 summary scores (Table 9).

Table 9: Mean Change in SF-36v1 Health Domain Scores Between end of On-demand and end of Prophylaxis Treatment Regimens^a

SF-36v1 Health Domain	Mean Change	95% Confidence Interval
Physical Functioning (PF)	0.89	(-1.02, 2.81)
Role Physical (RP)	3.56	(0.32, 6.79)
Bodily Pain (BP)	4.13	(1.63, 6.62)
General Health (GH)	1.36	(-0.72, 3.45)
Vitality (VT)	0.21	(-2.22, 2.63)
Social Functioning (SF)	1.72	(-0.57, 4.00)
Role Emotional (RE)	-1.29	(-3.78, 1.19)
Mental Health (MH)	-0.20	(-2.89, 2.49)
Physical Component Score	3.56	(1.56, 5.56)
Mental Component Score	-1.22	(-3.66, 1.23)

^a Positive change values are in the favourable direction.

Smaller diluent vial (2 mL sWFI) for strengths up to 1500 IU inclusive (from 5 mL sWFI to 2 mL sWFI)

An open label, randomised, crossover clinical study was conducted in 35 evaluable subjects diagnosed with severe hemophilia A (factor VIII [FVIII] activity \leq 1% of normal) to investigate the PK parameters and safety of a single dose of ADVATE (50 IU/kg \pm 100 IU) reconstituted in two different volumes of sterilised water for injections (sWFI, 2 mL or 5 mL). Subjects were randomized (1:1) to receive an infusion with ADVATE reconstituted in 2 mL followed by an infusion with ADVATE reconstituted in 5 mL sWFI or vice versa.

Results of this clinical study are summarised in Table 10 below.

Table 10: PK Parameters for Adolescent/Adult Cohort (Study 060702: PP Dataset)

Parameter	2 mL infusion		5 mL infusion	
	Mean (geometric mean) value for 2 mL infusion	SD (2 mL)	Mean (geometric mean) value for 5 mL infusion	SD (5 mL)
AUC _{0-48h} (IU h/dL)	1298.67	380.60	1363.56	487.57
C _{max} (IU/dL)	104.42	19.35	107.89	17.95
Adjusted <i>in vivo</i> IR ¹ (IU/dL:IU/kg)	1.93	0.35	2.00	0.36
Half-life (h)	12.54	3.80	12.50	2.89
C _L (mL/(kg/h))	3.85	0.95	3.81	1.20
MRT (h)	14.79	5.24	14.34	4.27
V _{ss} (dL/kg)	0.54	0.13	0.51	0.13

Abbreviations: PP = per-protocol, SD = standard deviation

¹ Mean adjusted *in vivo* incremental recovery (IR) values were computed using C_{max}.

5.2 PHARMACOKINETIC PROPERTIES

A randomized, crossover pharmacokinetic comparison of ADVATE (rAHF-PFM) and RECOMBINATE (rAHF) was conducted in the context of a pivotal Phase 2/3 study. Pharmacokinetic parameters area under the plasma curve versus time (AUC), C_{max}, mean residence time (MRT) and volume distribution in steady state [V_{ss}] were calculated from factor VIII activity measurements in blood samples obtained immediately before and at standardised time intervals up to 48 hours following each infusion. The results are shown in Table 11.

Table 11: Pharmacokinetic Parameters for ADVATE (rAHF-PFM) and RECOMBINATE (rAHF)

Parameter	RECOMBINATE (rAHF)		ADVATE (rAHF-PFM)	
	N	Mean ± sd	N	Mean ± sd
AUC _(0-48h) (IU.h/dL)	30	1530 ± 380	30	1534 ± 436
<i>In vivo</i> recovery (IU/dL/kg)	30	2.59 ± 0.52	30	2.41 ± 0.50
Half life (t _{1/2})	30	11.24 ± 2.53	30	11.98 ± 4.28
C _{max} (IU/dL)	30	129 ± 27	30	120 ± 26
MRT (h)	30	14.52 ± 3.81	30	15.68 ± 6.21
V _{ss} (dL/kg)	30	0.46 ± 0.10	30	0.47 ± 0.10
C _L (dL/kg/hr)	30	0.03 ± 0.01	30	0.03 ± 0.01

For the pharmacokinetic parameters AUC(0-48h) and the *in vivo* recovery, the 90 % confidence intervals for the ratios of the mean values for the test and control articles were within the pre-established bioequivalence limits of 0.80 and 1.25 for the per-protocol (n=30) study population. This was also true in the intent-to-treat study (n= 50) population for the total AUC and *in vivo* recovery. In addition, *in vivo* recovery at the onset of treatment and after 75 exposure days was compared for 62 subjects. Results indicated no significant change in the *in vivo* recovery at the onset of treatment and after 75 exposure days.

5.3 PRECLINICAL SAFETY DATA

Genotoxicity

Mutagenity studies to evaluate genetic toxicity potential of ADVATE have not been performed.

Carcinogenicity

Long-term studies in animals to evaluate carcinogenic potential of ADVATE have not been performed.

6 PHARMACEUTICAL PARTICULARS

6.1 LIST OF EXCIPIENTS

The amounts of the inactive ingredients are constant in all strengths.

Table 12: Unit Formulation

ADVATE	250 IU	500 IU	1000 IU	1500 IU	2000 IU	3000 IU	4000 IU
Inactive ingredient:	(mg)	(mg)	(mg)	(mg)	(mg)	(mg)	(mg)
Trehalose	40.0	40.0	40.0	40.0	40.0	40.0	40.0
Histidine	8.0	8.0	8.0	8.0	8.0	8.0	8.0
Trometamol	6.0	6.0	6.0	6.0	6.0	6.0	6.0
Sodium Chloride	26.5	26.5	26.5	26.5	26.5	26.5	26.5
Calcium Chloride	1.3	1.3	1.3	1.3	1.3	1.3	1.3
Glutathione (reduced)	0.4	0.4	0.4	0.4	0.4	0.4	0.4
Polysorbate 80	0.5	0.5	0.5	0.5	0.5	0.5	0.5
Mannitol	160.0	160.0	160.0	160.0	160.0	160.0	160.0

For active ingredients, refer to Section 2 QUALITATIVE AND QUANTITATIVE COMPOSITION.

6.2 INCOMPATIBILITIES

Incompatibilities were either not assessed or not identified as part of the registration of this medicine.

6.3 SHELF LIFE

2 years.

The product is stable for the duration of the specified shelf life when stored in the specified temperature storage condition. ADVATE should be administered at room temperature not more than 3 hours after reconstitution.

Product is for single use in one patient only. Do not use beyond the expiration date printed on the label. Discard any residue.

6.4 SPECIAL PRECAUTIONS FOR STORAGE

ADVATE should be stored at 2°C – 8°C for the duration of its shelf life. Do not freeze.

In the case of a need for ambulatory use, ADVATE may be kept at or below 25 °C (room temperature) for a single period of up to 6 months and then discarded.

After ADVATE has been stored at room temperature, it should not be re-refrigerated. Do not use beyond the expiration date printed on the label. Protect from light.

6.5 NATURE AND CONTENTS OF CONTAINER

ADVATE powder comes in single-dose vials. Each vial is labelled for strength in IU, and is packaged together with either a 2 mL or 5 mL sWFI vial, 1 BaxJect II or BaxJect III device for reconstitution, 1 mini-infusion set, 1 10 mL sterile disposable syringe for administration, 2 alcohol swabs and 2 plasters.

Please refer to the table below for details of the ADVATE and diluent vials, and the available strengths for each diluent volume.

Table 13

	ADVATE 5 mL sWFI*	ADVATE 2 mL sWFI*
ADVATE powder vial type	single-dose vials of neutral borosilicate glass hydrolytic type I	single-dose vials of neutral borosilicate glass hydrolytic type I
ADVATE powder vial stopper	teflon coated butyl rubber	teflon coated butyl rubber
Available strengths (IU)	250, 500, 1000, 1500, 2000, 3000, 4000	250, 500, 1000, 1500
sWFI (diluent) vial type	neutral borosilicate glass hydrolytic type I	neutral borosilicate glass hydrolytic type I
sWFI vial stopper	chlorobutyl rubber	bromobutyl rubber
sWFI vial cap colour	grey	clear, colourless

* Note: Not all presentations may be marketed.

Needleless Transfer Device (BAXJECT)

The product is accompanied by a needleless transfer device designed for transferring and mixing drugs contained in two vials (product and diluent). Each Needleless Transfer Device has a two-vial holder, a two-sided siliconised piercing plastic spike for penetration into the rubber stoppers of the two vials, a stopcock with an embedded filter, and a female port designed for connection to a syringe (Refer to Section 4.2 for illustrations).

6.6 SPECIAL PRECAUTIONS FOR DISPOSAL

Discard any unused preparation appropriately.

In Australia, any unused medicine or waste material should be disposed of by taking to your local pharmacy.

6.7 PHYSICOCHEMICAL PROPERTIES

Chemical Name: Recombinant Coagulation Factor VIII (rch)

Laboratory Code: Recombinant Antihæmophilic FVIII, Plasma/Albumin Free Method (rAHF-PFM)

Chemical structure

The chemical structure of rAHF-PFM is that of a dimeric glycoprotein, which has been shown to have a similar amino acid sequence with that of the human plasma derived factor VIII. Amino acid analysis of the purified glycosylated protein demonstrated that it constitutes 2332 amino acids with a molecular mass of approximately 280 kDa. Thus, the rAHF-PFM is a full length factor VIII.

CAS numbers

Octacog alfa: CAS No. 139076-62-3

7 MEDICINE SCHEDULE (POISONS STANDARD)

Unscheduled.

8 SPONSOR

Shire Australia Pty Limited
Level 39
225 George Street
Sydney, NSW 2000
Australia.
Telephone: 1800 012 612
www.shireaustralia.com.au

9 DATE OF FIRST APPROVAL

AUST R 100384 (ADVATE 250 IU)	04 April 2005
AUST R 100385 (ADVATE 500 IU)	04 April 2005
AUST R 100386 (ADVATE 1000 IU)	04 April 2005
AUST R 100387 (ADVATE 1500 IU)	04 April 2005
AUST R 136204 (ADVATE 2000 IU)	23 January 2008
AUST R 150366 (ADVATE 3000 IU)	13 November 2008
AUST R 214709 (ADVATE 4000 IU)	16 July 2014

10 DATE OF REVISION

21 June 2018.

SUMMARY TABLE OF CHANGES

Section Changed	Summary of new information
All	Australian PI updated to new SPC format.
4.2, 4.8, 5.1, 5.2, 6.5	Minor editorial change to update sponsor name; images updated due to sponsor change; correction of typographical errors; included table numbers for all tables; corrected misplaced table footer.
4.2	Administration section re-arranged, re-numbered and re-grouped for more clarity.
6.7	Included CAS number
8	Change in sponsor contact details

ADVATE® is a trademark of Baxalta Incorporated, a wholly-owned, indirect subsidiary of Shire plc.

Shire and the Shire Logo are trademarks of Shire Pharmaceutical Holdings Ireland Limited or its affiliates.